

SILVER SHIELD CR[®] CHAIN

STRONGER PROTECTION WITH THE TOP-PERFORMING CORROSION-RESISTANT COATING

Silver Shield CR[®] chain offers increased corrosion resistance when applications are subject to high-moisture or mildly caustic or acidic environments. Our standard heat-treated carbon-steel components coated with the zinc-based Silver Shield CR protection provide extended corrosion resistance. Increased reliability and an inventory of multiple sizes is available to help your operations experience less downtime.

- Specially formulated coating offers superior corrosion resistance in high-moisture environments and washdown applications
- Fewer chain replacements results in lower total cost of operations
- Maintains same working loads as carbon-steel chain
- Fully interchangeable with carbon-steel ANSI chains*
- Full variety of sizes and configurations; custom engineering-class chain available (customer-specific stocking program also available)
- Available with chrome pin for increased wear life due to reduction in rate of wear between the pin and bushing

*Interchangeable with stainless-steel ANSI chain. Contact your Drives representative for application review.



Based on the industry standard salt-spray test, Silver Shield CR chain provides more than double the corrosion resistance of any other zinc-coated chain currently on the market.

1. Drives
 - Silver Shield CR
 - 1,000+ hours
 - Before rust showed



2. Japan Manufacturer
 - 500 hours
 - Rust showed



3. German Manufacturer
 - 300 hours
 - Rust showed



1pH	3pH	5pH	7pH	9pH	11pH	13pH
Acidic			Neutral	Caustic		
Stainless Steel			Nickel Plated Silver Shield CR	Stainless Steel		

Note: As the pH becomes more acidic or caustic, a higher corrosion resistant stainless steel material may be required.

Applications

Food and Beverage

- Washdown applications
- Incidental contact with food (no direct contact with food)
- pH levels between 5 and 9

Packaging

- Washdown applications
- pH levels between 5 and 9

Agriculture

- Used on planters and sprayers in agriculture applications

General

- Washdown applications
- Chains exposed to weather conditions
- Environments with moisture exposure or high humidity

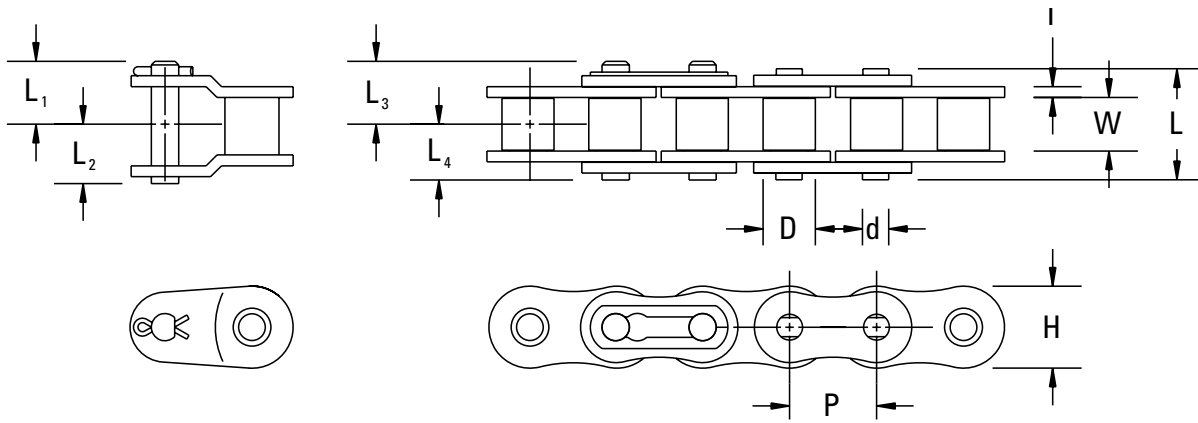

SILVER SHIELD CR CHAIN

Chain No.	Pitch P	Main Roller Link Inside Width W	Roller Dia. D	Link Plate		Pin						Average Weight lbs./ft. kg/m
				H	T	d	L	L ₁	L ₂	L ₃	L ₄	
				in. mm	in. mm	in. mm	in. mm	in. mm	in. mm	in. mm	in. mm	
40CR	0.500 12.70	0.312 7.92	0.312 7.92	0.472 11.99	0.060 1.52	0.156 3.96	0.630 16.00	0.404 10.26	0.317 8.05	0.377 9.58	0.315 8.00	0.420 0.625
50CR	0.625 15.88	0.376 9.55	0.400 10.16	0.590 14.99	0.080 2.03	0.200 5.08	0.795 20.19	0.489 12.42	0.399 10.13	0.489 12.42	0.398 10.11	0.713 1.061
60CR	0.750 19.05	0.500 12.70	0.469 11.91	0.705 17.91	0.094 2.39	0.234 5.94	0.996 25.30	0.600 15.24	0.498 12.65	0.648 16.46	0.498 12.65	1.067 1.588
80CR	1.000 25.40	0.626 15.90	0.625 15.88	0.943 23.95	0.125 3.18	0.313 7.95	1.283 32.59	0.768 19.51	0.638 16.21	0.857 21.77	0.642 16.31	1.868 2.780
100CR	1.250 31.75	0.755 19.18	0.750 19.05	1.180 29.97	0.156 3.96	0.375 9.53	1.595 40.51	0.908 23.06	0.785 19.94	0.912 23.16	0.785 19.94	2.680 3.988
120CR	1.500 38.10	1.000 25.40	0.875 22.23	1.425 36.20	0.187 4.75	0.437 11.10	1.955 49.66	1.119 28.42	1.071 27.20	1.119 28.42	0.989 25.12	3.980 5.923
140CR	1.750 44.45	1.000 25.40	1.000 25.40	1.663 42.24	0.220 5.59	0.500 12.70	2.136 54.25	1.253 31.83	1.150 29.21	1.253 31.83	1.068 27.13	5.030 7.485
160CR	2.000 50.80	1.250 31.75	1.125 28.58	1.889 48.23	0.250 6.35	0.562 14.27	2.538 64.47	1.454 36.93	1.370 34.80	1.454 36.93	1.209 30.71	6.790 10.105

NOTE: Dimensions are subject to change. Contact your Drives representative to obtain certified prints for design and construction.

NOTE: Solutions used in washdown applications may not be compatible with Silver Shield CR coating. Contact your Drives representative for more information.

Backed by Timken

With Silver Shield CR chain, you have the benefit of Timken technical support and engineering expertise. The strength of our CoLinx distribution network gives you access to the right product at the right time, while offering a cost savings in shipping and handling.

For More Information: 877-484-6536



CHOOSE TIMKEN

See why Timken is your expert in bearings and mechanical power transmission by visiting our catalogs at www.timkencatalogs.squawq.com or scanning the QR code at left.

WARNING

Failure to observe the following warnings could create a risk of death or serious injury.

Do not weld to Silver Shield CR® chain as it will release toxic fumes.

