

 **DIAMOND**[®]
BY TIMKEN

SAPPHIRE[®]
BY DIAMOND



AGRICULTURE PRODUCT GUIDE



TABLE OF CONTENTS

Diamond Series

Standard Series	4
Heavy Series	4
Double Pitch	5
Power Transmission Chain	5
Conveyor Chain	5

Sapphire Series

Standard Series	6
Heavy Series	6
Double Pitch	7
Power Transmission Chain	7
Conveyor Chain	7

Agriculture Chain

S & C Type Chain	8
AG Conveyor Chain	8
Citrus Chain	9
Cotton Module Chain	9
Cornhead Gathering Chain	9

Agricultural Attachments	10-14
--------------------------	-------



Every Calling is Great, When Greatly Pursued.

OLIVER WENDELL HOLMES



At the Diamond Chain Company, the calling to design and manufacture the world's highest-performing roller chain is greatly pursued every day by teams of passionate technical experts who have made your success their life's work. It's that intensity of focus that some of the world's greatest inventors trusted to provide the drive chains they needed to transform the world. From the Wright Brothers, to Henry Ford, to the global leaders of our time, Diamond® chain is the roller chain most trusted to perform, when performance matters most.

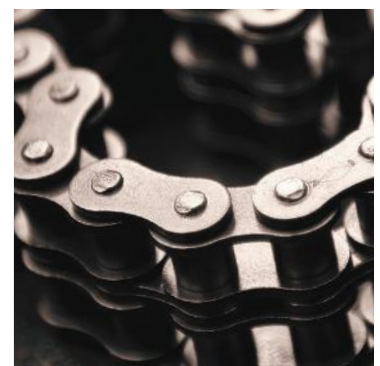



STANDARD SERIES CHAIN

SINGLE AND MULTI-STRAND

Diamond Standard Series Chains are built to ASME / ANSI B29.1 standards for dimensions, interoperability, and sprocket fit and exceed the established standards for tensile strength.

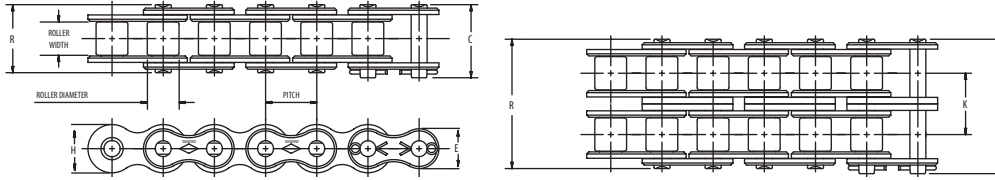

Dimensions in Inches

ASME/ANSI Number	Pitch Inches	Roller Width	Roller Diameter	Pin Diameter	Link Plate Thickness	C	R	K	Pounds Per Foot	Average Tensile Strength	E**	H**
35	3/8	3/16	.200	.141	.050	0.56	0.50	0.21	2100	0.308	0.356
40	1/2	5/16	.312	.156	.060	0.72	0.67	0.41	4000	0.410	0.475
40-2	1/2	5/16	.312	.156	.060	1.29	1.24	0.566	0.80	8000	0.410	0.475
41	1/2	1/4	.306	.141	.050	0.65	0.57	0.26	2400	0.310	0.383
50	5/8	3/8	.400	.200	.080	0.89	0.83	0.68	6600	0.512	0.594
60	3/4	1/2	.469	.234	.094	1.11	1.04	0.99	8500	0.615	0.713
60-2	3/4	1/2	.469	.234	.094	2.01	1.94	0.897	1.95	17000	0.615	0.713
80	1	5/8	.625	.312	.125	1.44	1.32	1.73	14500	0.820	0.950
80-2	1	5/8	.625	.312	.125	2.59	2.47	1.153	3.37	29000	0.820	0.950
100	1 1/4	3/4	.750	.375	.156	1.73	1.61	2.51	24000	1.025	1.188

*Chains are rollerless -- dimension shown is bushing diameter.

ASME/ANSI 60 and larger chains are available as cottered or riveted type design.

Multiple strand chains are available with slip-fit (standard) or press-fit center plates.

** Maximum values are shown.

HEAVY SERIES CHAIN

Diamond Heavy Series Chains are built to ASME / ANSI B29.1 standards and utilize link plates from the next larger size of chain. Heavy Series chains are intended for applications subject to heavy shock loads, starts and stops, and forward and reverse travel.

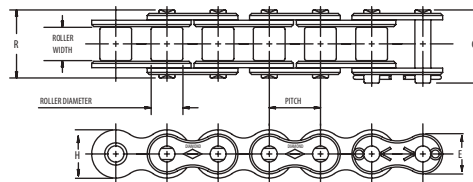

Dimensions in Inches

ASME/ANSI Number	Pitch Inches	Roller Width	Roller Diameter	Pin Diameter	Link Plate Thickness	C	R	K	Pounds Per Foot	Average Tensile Strength	E**	H**
60H	3/4	1/2	.469	.234	.125	1.24	1.17	1.18	8500	.615	.713
80H	1	5/8	.625	.312	.156	1.57	1.45	2.02	14500	.820	.950
100H	1 1/4	3/4	.750	.375	.187	1.86	1.74	2.82	24000	1.025	1.188

ASME/ANSI 60 and larger chains are available as cottered or riveted type design.

Multiple strand chains are available with slip-fit (standard) or press-fit center plates.

** Maximum values are shown.



DOUBLE-PITCH POWER TRANSMISSION ROLLER CHAIN

These chains, produced to ASME/ANSI B29.3 standards, have figure-eight style link plates. Their dimensions are similar to Standard Series chains with the exception of the pitch, which is twice that of the Standard Series chains. The increase in pitch means that only half the number of component parts are required per foot which can significantly lower the cost. Typical uses for these types of chains include light load drives commonly found in agricultural machinery.

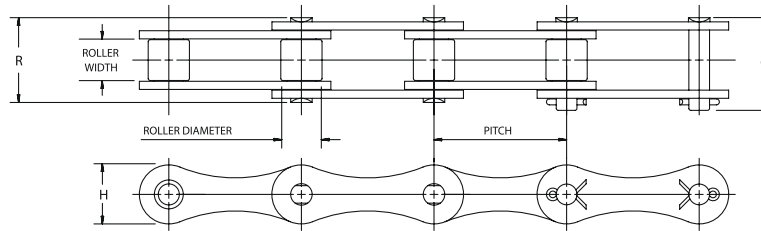

Dimensions in Inches

ASME/ANSI Number	Pitch Inches	Roller Width	Roller Diameter	Pin Diameter	Link Plate Thickness	C	R	Pounds Per Foot	Average Tensile Strength	H*
2040	1	5/16	.312	.156	.060	.76	.68	0.28	3700	.475
2050	1 1/4	3/8	.400	.200	.080	.92	.84	0.52	6100	.594
2060	1 1/2	1/2	.469	.234	.094	1.11	1.05	0.72	8500	.712

ASME/ANSI 60 and larger chains are available as cottered or riveted type design.

*Maximum values are shown.

DOUBLE-PITCH CONVEYOR ROLLER CHAIN

Produced to ASME/ANSI B29.4 standards, these chains are used in conveyor applications when loads are low and speeds are moderate. They are similar to the Double-Pitch Power Transmission chains, but with link plates that have an oval contour, and can be produced with either standard or over-sized rollers. They are most often found working on conveyors of all shapes and sizes and can be supplied with one or more of our many attachments to carry or convey products.

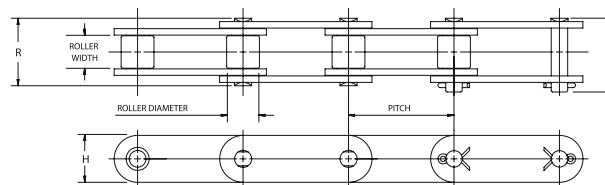

Dimensions in Inches

ASME/ANSI Number	Pitch Inches	Roller Width	Roller Diameter	Pin Diameter	Link Plate Thickness	C	R	Pounds Per Foot	Average Tensile Strength	H*
C2040	1	5/16	.312	.156	.060	.76	.68	0.34	3700	.475
C2042	1	5/16	.625	.156	.060	.76	.68	0.50	3700	
C2050	1 1/4	3/8	.400	.200	.080	.92	.84	0.58	6100	.594
C2052	1 1/4	3/8	.750	.200	.080	.92	.84	0.81	6100	
C2060H	1 1/2	1/2	.469	.234	.125	1.25	1.18	1.05	8500	.712
C2062H	1 1/2	1/2	.875	.234	.125	1.25	1.18	1.42	8500	

ASME/ANSI 60 and larger chains are available as cottered or riveted type design.

*Maximum values are shown.

SAPPHIRE®

STANDARD SERIES CHAIN

SINGLE AND MULTI-STRAND

Sapphire Standard Series Chains are built to ASME / ANSI B29.1 standards.

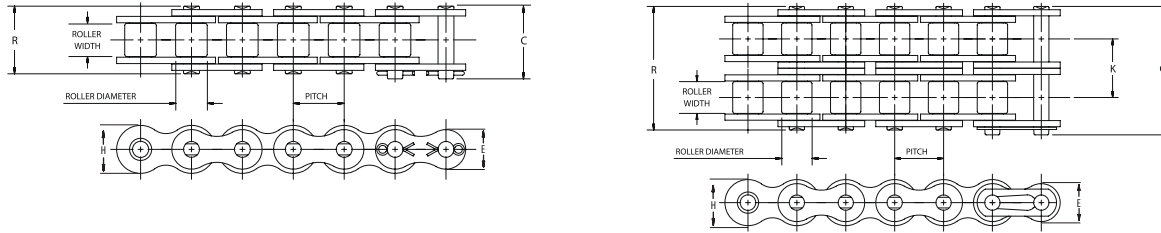

Dimensions in Inches

ASME/ANSI Number	Pitch Inches	Roller Width	Roller Diameter	Pin Diameter	Link Plate Thickness	C	R	K	Pounds Per Foot	Minimum Tensile Strength	E**	H**
35	3/8	3/16	*.200	.141	.050	0.56	0.50	0.21	1760	0.308	0.356
40	1/2	5/16	.312	.156	.060	0.72	0.67	0.41	3125	0.410	0.475
40-2	1/2	5/16	.312	.156	.060	1.29	1.24	0.566	0.80	6250	0.410	0.475
41	1/2	1/4	.306	.141	.050	0.65	0.57	0.26	1500	0.310	0.383
50	5/8	3/8	.400	.200	.080	0.89	0.83	0.68	4880	0.512	0.594
50-2	5/8	3/8	.400	.200	.080	1.60	1.55	0.713	1.320	9760	0.615	0.713
60	3/4	1/2	.469	.234	.094	1.11	1.04	0.99	7030	0.615	0.713
60-2	3/4	1/2	.469	.234	.094	2.01	1.94	0.897	1.95	14060	0.615	0.713
80	1	5/8	.625	.312	.125	1.44	1.32	1.73	12500	0.820	0.950
80-2	1	5/8	.625	.312	.125	2.59	2.47	1.153	3.37	25000	0.820	0.950
100	1 1/4	3/4	.750	.375	.156	1.73	1.61	2.51	19530	1.025	1.188

*Chains are rollerless -- dimension shown is bushing diameter.
 ASME/ANSI 60 and larger chains are available as cottered or riveted type design.
 Multiple strand chains are available with slip-fit (standard) center plates.
 ** Maximum values are shown.

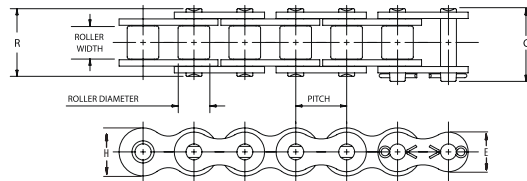

HEAVY SERIES CHAIN

Sapphire Heavy Series Chains are built to ASME / ANSI B29.1 standards.

Dimensions in Inches

ASME/ANSI Number	Pitch Inches	Roller Width	Roller Diameter	Pin Diameter	Link Plate Thickness	C	R	Pounds Per Foot	Minimum Tensile Strength	E**	H**
50H	5/8	3/8	.400	.200	.094	0.86	0.93	0.79	5886	.512	.594
60H	3/4	1/2	.469	.234	.125	1.24	1.17	1.18	7030	.615	.713
80H	1	5/8	.625	.312	.156	1.57	1.45	2.02	12500	.820	.950
100H	1 1/4	3/4	.750	.375	.187	1.86	1.74	2.83	19530	1.025	1.188

ASME/ANSI 60 and larger chains are available as cottered or riveted type design.
 Multiple strand chains are available with slip-fit (standard) center plates.
 ** Maximum values are shown.

SAPPHIRE®

DOUBLE-PITCH POWER TRANSMISSION ROLLER CHAIN

Sapphire Double-Pitch Power Transmission Chains are built to ASME / ANSI B29.3 standards.

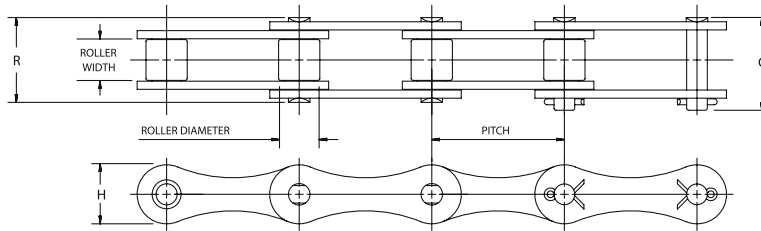

Dimensions in Inches

ASME/ANSI Number	Pitch Inches	Roller Width	Roller Diameter	Pin Diameter	Link Plate Thickness	C	R	Pounds Per Foot	Minimum Tensile Strength	H*
2040	1	5/16	.312	.156	.060	.76	.68	0.28	3125	.475
2050	1 1/4	3/8	.400	.200	.080	.92	.84	0.52	4880	.594
2060	1 1/2	1/2	.469	.234	.094	1.11	1.05	0.72	7030	.712

ASME/ANSI 60 and larger chains are available as cottered or riveted type design.

*Maximum values are shown.

DOUBLE-PITCH CONVEYOR ROLLER CHAIN

Sapphire Double-Pitch Conveyor Series Chains are built to ASME / ANSI B29.4 standards.

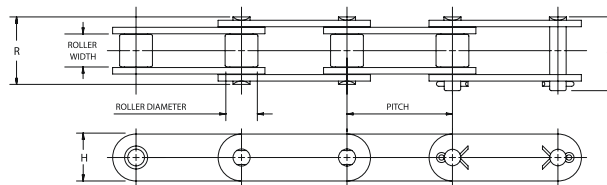

Dimensions in Inches

ASME/ANSI Number	Pitch Inches	Roller Width	Roller Diameter	Pin Diameter	Link Plate Thickness	C	R	Pounds Per Foot	Minimum Tensile Strength	H*
C2040	1	5/16	.312	.156	.060	.76	.68	0.34	3125	.475
C2042	1	5/16	.625	.156	.060	.76	.68	0.50	3125	.475
C2050	1 1/4	3/8	.400	.200	.080	.92	.84	0.58	4880	.594
C2052	1 1/4	3/8	.750	.200	.080	.92	.84	0.81	4880	.594
C2060H	1 1/2	1/2	.469	.234	.125	1.25	1.18	1.05	7030	.712
C2062H	1 1/2	1/2	.875	.234	.125	1.25	1.18	1.42	7030	.712

ASME/ANSI 60 and larger chains are available as cottered or riveted type design.

*Maximum values are shown.

SAPPHIRE®

S & C ROLLER CHAIN

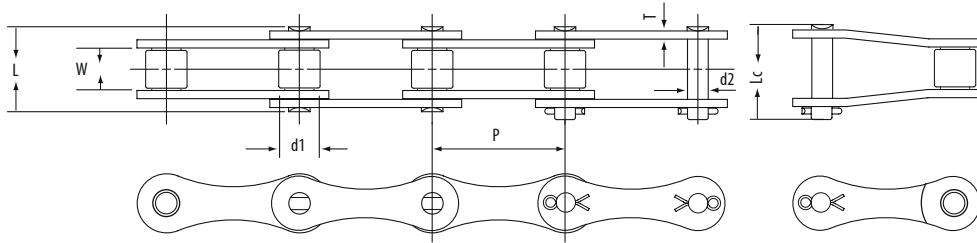

Dimensions in Inches

Part Number	Pitch P	Roller W min	Roller d1 max	Pin Diameter d2 max	Pin Length L max	Pin Length Lc max	Link Plate Height H	Link Plate Thickness T	Average Tensile Strength
S32	1.150	.625	.450	.176	1.039	1.102	.528	.071	4960
S42	1.375	.768	.562	.276	1.350	1.457	.776	.110	11463
S45	1.630	.875	.600	.230	1.484	1.591	.677	.110	8377
S52	1.500	.875	.600	.230	1.484	1.591	.677	.110	8377
S55	1.630	.875	.700	.230	1.484	1.591	.677	.110	8377
S62	1.650	1.000	.750	.230	1.587	1.693	.677	.098	8377
S77	2.297	.875	.719	.351	1.701	1.827	1.031	.157	16534
S88	2.609	1.125	.900	.351	1.961	2.087	1.031	.157	16534
A550	1.630	.780	.664	.283	1.402	1.553	.795	.106	12125
A620	1.654	.965	.705	.283	1.661	1.799	.795	.126	13227

AGRICULTURAL ROLLER CHAIN

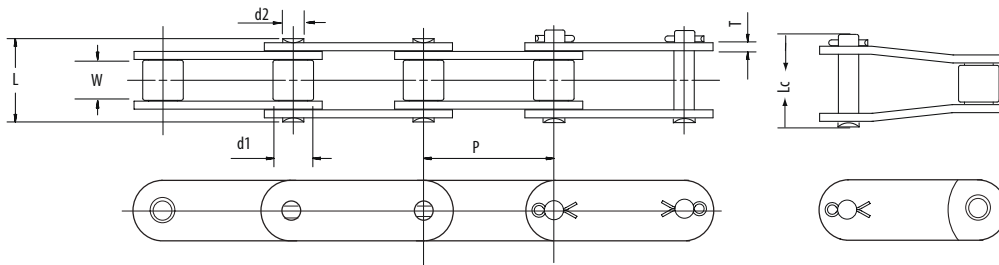

Dimensions in Inches

Part Number	Pitch P	Roller W min	Roller d1 max	Pin Outer Diameter d2 max	Pin Length L max	Pin Length Lc max	Link Plate Height H max	Link Plate Thickness T	Average Tensile Strength
CA550	1.630	.780	.664	.283	1.404	1.526	.795	.106	12125
CA555	1.630	.500	.657	.283	1.185	1.303	.795	.126	13227
CA557	1.630	.780	.701	.315	1.472	1.598	.878	.126	16534
CA620	1.654	.965	.705	.283	1.646	1.780	.795	.126	13227

SAPPHIRE®

CITRUS ROLLER CHAIN

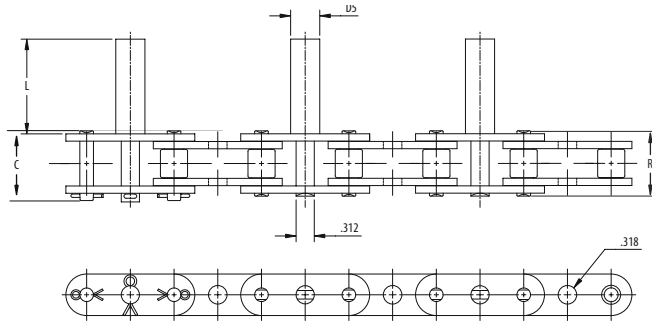

Dimensions in Inches

Part Number	Pitch	Roller Width	Roller Diameter	Pin Diameter	C	R	DS	L	Link Plate Thickness	Minimum Tensile Strength
C2060H-D5 Type 1	1 ½	½	.469	.234	1.25	1.18	1/2	1.625	.125	7030
C2060H-D5 Type 2	1 ½	½	.469	.234	1.25	1.18	9/16	1.625	.125	7030

COTTON MODULE ROLLER CHAIN

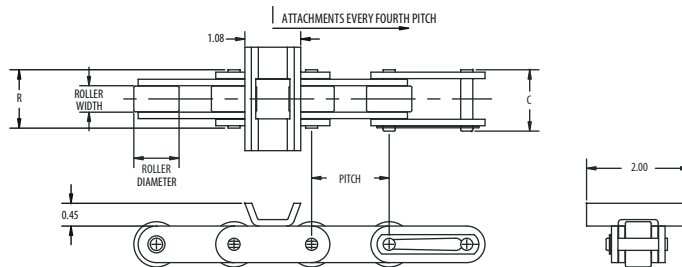

Dimensions in Inches

Part Number	Pitch	Roller Width	Roller Diameter	Pin Diameter	C	R	Link Plate Thickness	Minimum Tensile Strength
C2062H	1 ½	½	.875	.234	1.25	1.18	.125	7030

CORNHEAD GATHERING CHAIN-STOCK ITEMS

Dimensions in Inches

Part Number	OEM CROSS-REFERENCE			Chain/Attachment Technical Data
	AGCO®	John Deere®	International Harvester®	
CA555 C6E 48-8	—	AN102009	176279C91	page 12-13
CA550 C17E 50-6	71505705	—	—	page 11
CA550 C11E 57-7	573640	—	—	page 12
CA550 C17E 57-7	574793/591122	—	—	page 11

Any cornhead gathering chains not listed above are available Made-To-Order in most chain/attachment combinations.

See page 10 – 13 or contact Diamond Chain for more information at 1-800-872-4246.

ATTACHMENTS

K1

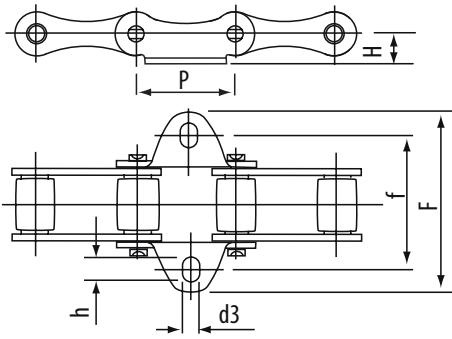

Dimensions in Inches

Part Number	P	f	F	H	d3	h
S32	1.150	1.689	2.402	.339	.209	.272
S42	1.375	2.123	2.949	.551	.327	.453
S45	1.630	2.000	2.953	.449	.335	.461
S52	1.500	2.315	3.071	.449	.327	.390
S55	1.630	2.123	2.953	.449	.335	.461
S62	1.650	2.630	3.756	.449	.256	.512
S77	2.297	2.874	4.000	.819	.327	.453
S88	2.609	3.752	4.701	.819	.327	.390

K8

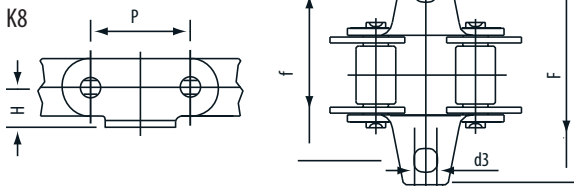

Dimensions in Inches

Part Number	P	f	F	H	d3
CA550	1.630	2.000	3.000	.500	.264
CA550	1.630	2.134	3.000	.500	.327

M1

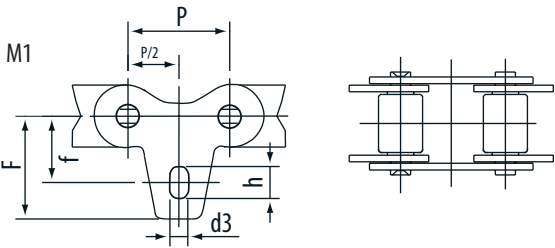

Dimensions in Inches

Part Number	P	f	F	hd	3
S32	1.150	.681	1.031	.209	.272
S42	1.375	.929	1.350	.327	.453
S45	1.630	.780	1.189	.327	.453
S52	1.500	.870	1.252	.327	.390
S55	1.630	.780	1.189	.327	.453
S62	1.650	.969	1.520	.327	.579
S77	2.297	1.429	1.969	.327	.453
S88	2.609	1.720	2.189	.327	.390

F4

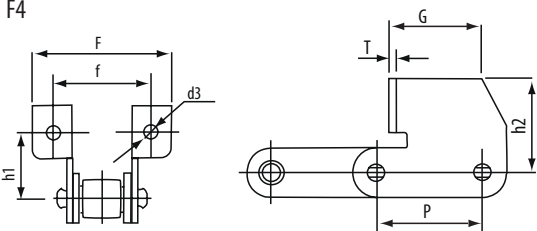

Dimensions in Inches

Part Number	P	f	F	h1	h2	T	d3	G
CA550	1.630	1.874	2.689	1.220	1.689	.106	.327	1.453
S45	1.630	2.283	3.543	.787	1.217	.106	.256	1.453
S5	1.630	2.283	3.543	.787	1.217	.106	.256	1.453

K1

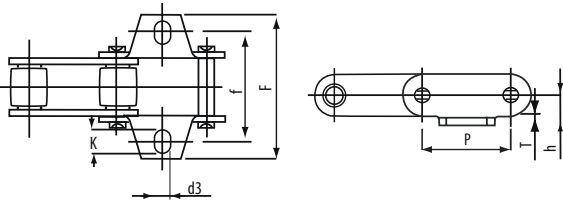

Dimensions in Inches

Part Number	P	f	F	H	d3	K	T
CA550	1.630	2.165	3.031	.573	.327	.417	.106

ATTACHMENTS

K1

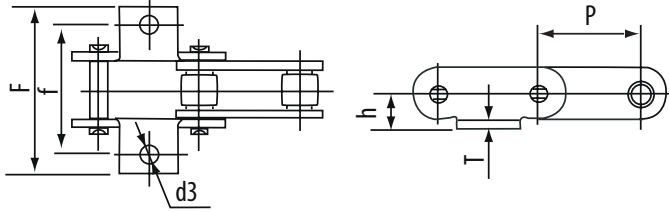

Dimensions in Inches

Part Number	P	f	F	H	d3	T
CA620	1.654	2.469	3.157	.453	.266	.126

C30 E

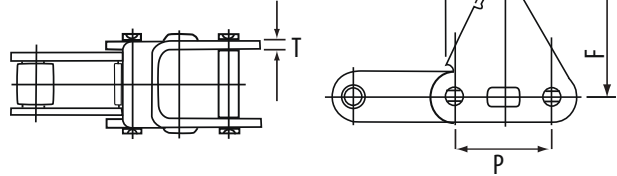

Dimensions in Inches

Part Number	P	a°	T	F
CA550	1.630	2.8°	1.06	2.000

CPE/7AUE

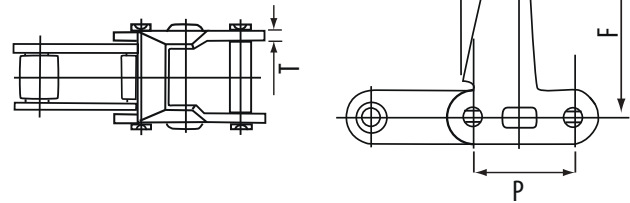

Dimensions in Inches

Part Number	P	a°	T	F
CA550	1.630	17°	.106	2.500
C2060H	1.500	22°	.126	2.252

CPE

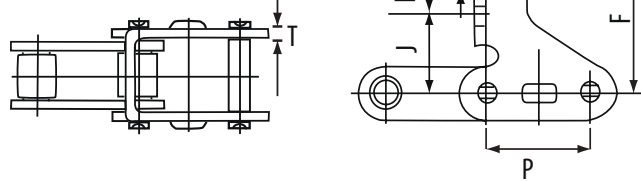

Dimensions in Inches

Part Number	P	K	J	d4	T	F
C2060H	1.500	1.000	.925	.232	.126	2.339

A1

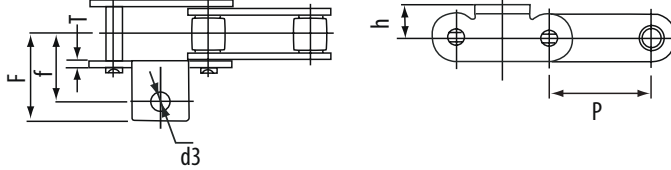

Dimensions in Inches

Part Number	P	f	F	H	T	d3
CA620	1.654	31.4°	1.579	.453	.126	.148

C17/C17 E

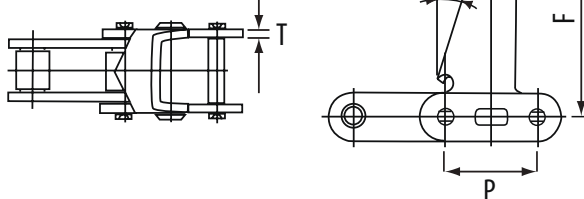

Dimensions in Inches

Part Number	P	a°	T	F
CA550	1.630	20°	.106	3.000
C2060H	1.500	22.50°	.126	2.311

ATTACHMENTS

C5E

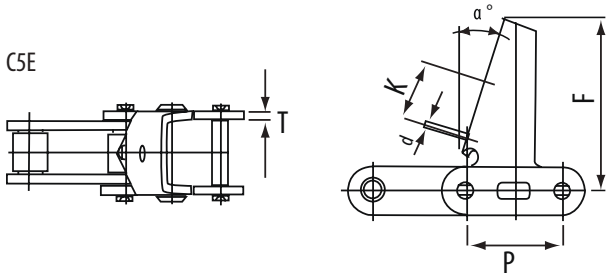

Dimensions in Inches

Part Number	P	a°	T	F	d	K
C2060H	1.630	22.5°	.126	2.252	.335	1.181

C11E/C11

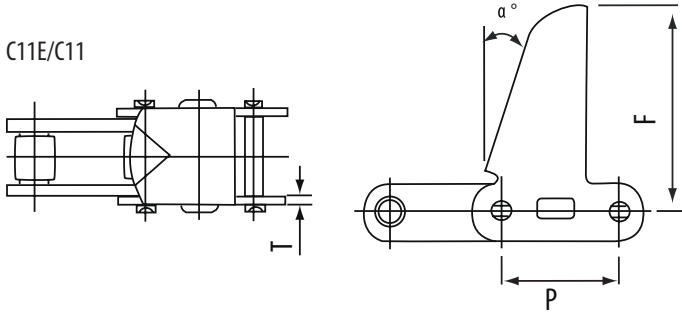

Dimensions in Inches

Part Number	P	a°	T	F
CA550	1.630	15°/17°	.106	2.500

C13E/C13

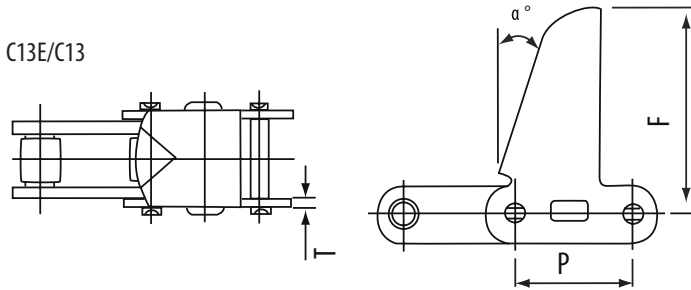

Dimensions in Inches

Part Number	P	a°	T	F
CA550	1.630	17°	.106	3.626
CA620	1.579	15°	.126	3.622

C30E

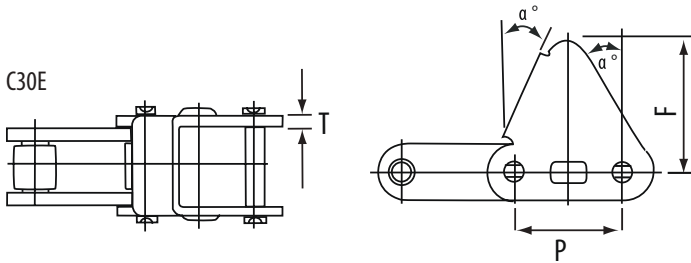

Dimensions in Inches

Part Number	P	a°	T	F
CA620	1.579	22.5°	.126	2.311

C6E

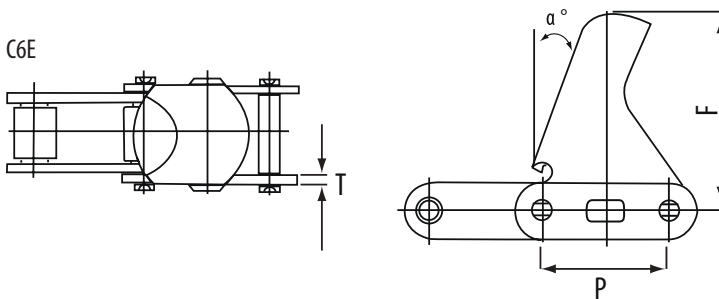

Dimensions in Inches

Part Number	P	a°	T	F
C2060H	1.500	23°	.126	2.500

ATTACHMENTS

C6E

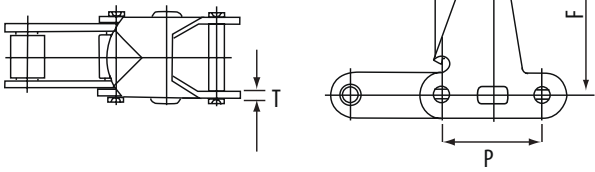

Dimensions in Inches

Part Number	P	a°	T	F
CA555	1.630	15°	.126	2.500

C6E

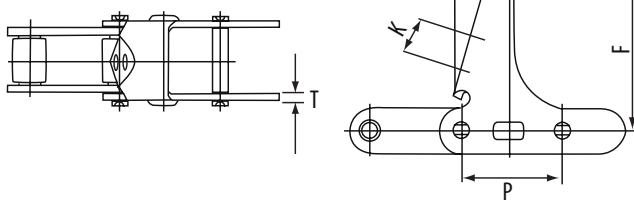

Dimensions in Inches

Part Number	P	a°	T	F
CA550	1.630	15°	.106	2.189

K19

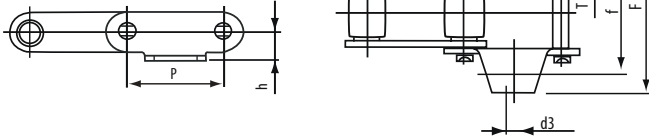

Dimensions in Inches

Part Number	P	f	F	h	d_3	T
CA550	1.630	2.000	2.811	.500	.266	.106

F14/F1

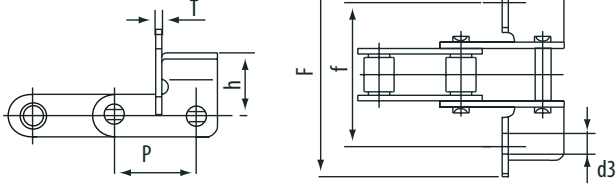

Dimensions in Inches

Part Number	P	f	F	h	d_3	T
CA550	1.630	3.126	4.126	1.252	.327	.106

A19

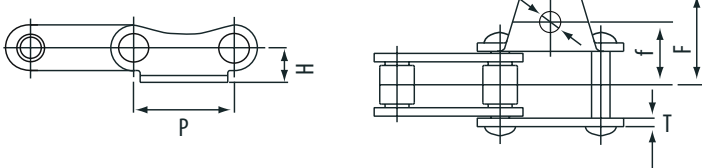

Dimensions in Inches

Part Number	P	f	F	h	G	d_3	T
CA550	1.630	1.000	1.500	.500	.874	.264	.106

NOTES

NOTES

DIAMOND® CHAIN COMPANY

Americas

Corporate Headquarters
402 Kentucky Avenue
Indianapolis, Indiana 46207
PH: 1-800 US CHAIN
1-800-872-4246
Fax: 1-317-633-2243

Dallas Service Center
9120 Premier Row
Dallas, Texas 75356
PH: 1-877-453-9128
Fax: 1-214-631-2374

Sacramento Service Center
1075 Triangle Court
West Sacramento, California 95605
PH: 1-877-453-9127
Fax: 1-916-372-5801
sales@diamondchain.com

Canada/Mexico
PH: 1-317-638-6431
www.diamondchain.com



United Kingdom

Unit 7 – 9
Blaydon Industrial Park
Chainbridge Road
Blaydon on Tyne
NE21 5AB
PH: 44-191-414-8822
sales@diamondchain.be
www.diamondchain.co.uk

Asia

Century Financial Tower, Unit 2005
No. 1 Suhua Road, SIP, Suzhou
Jiangsu Province, China 215021
PH: +86 512-6265-3075
salescn@diamondchain.com

